

Specifications

Model	GTH™-3007	
Measurements	Metric	Imperial
Lifting height maximum	6.89 m	22 ft 7 in
Lifting capacity maximum	3,000 kg	6,614 lbs
Lift capacity at maximum height	2,500 kg	5,511 lbs
Lift capacity at maximum reach	800 kg	1,764 lbs
Forward reach maximum	3.86 m	12 ft 8 in
Reach at maximum height	76 cm	2 ft 6 in
A Height****	2.30 m	7 ft 7 in
B Height at steering wheel	1.4 m	4 ft 7 in
C Width	1.99 m	6 ft 6 in
D Cab width	86 cm	2 ft 10 in
E Track	1.59 m	5 ft 3 in
F Wheelbase	2.66 m	8 ft 9 in
G Length at front wheels	4.07 m	13 ft 4 in
H Length at fork-holder plate	4.66 m	15 ft 3 in
I Ground clearance	43 cm	1 ft 5 in
J Overall length	5.86 m	19 ft 3 in
M1 Obstruction angle		90°
M2 Departure angle		38°

Measurements

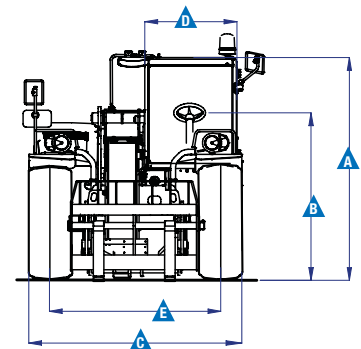
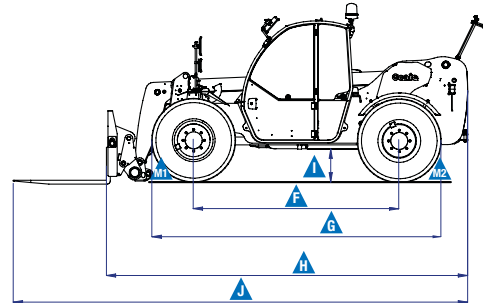

Productivity

Inside/outside turning radius	2.55 m/4.4 m	8 ft 4 in/14 ft 5 in
Break-out force*	4,270 kg	9,414 lbs
Towing capacity at dynamometer*	3,100 kg	6,834 lbs
Drive speed max.	30 km/h	18.6 mph
Fork-holder plate rotation		128°
Tyres (DIN 70361)	405/70-20" PR14 8 holes wheel disc	
Lifting/lowering speed**		9 sec/7 sec
Extension/retraction speed**		10 sec/5 sec

Power

Engine	Deutz TD 2.9 L4, 4-cylinder turbo diesel 55.4 kW (74 hp (55.4 kW), stage IIIA	
Transmission	Hydrostatic variable displacement pump linked to variable displacement motor. Both piston type.	
Service pumps	Boom & Control system gear pump: 280 Bar, 78 L/min.	
Petrol tank capacities	90 L	23.7 gal
Engine oil capacities	8 L	2.1 gal
Hydraulic oil tank capacities	75 L	19.8 gal

Weight***	6,060 kg	13,360 lbs
-----------	----------	------------

Standards Compliance

AS 1418.19

Operating cab conforms to ISO 3471 (ROPS) and ISO 3449 (FOPS)

* with 800 L shovel SAE J 732/80

** Without load

*** Weight will vary depending on options and/or country standards

**** Rotating beacon in raised operational position. Height reduced by 0.15 m (6 in) when rotating beacon is in lowered transport position.

Load Charts

On tyres with forks

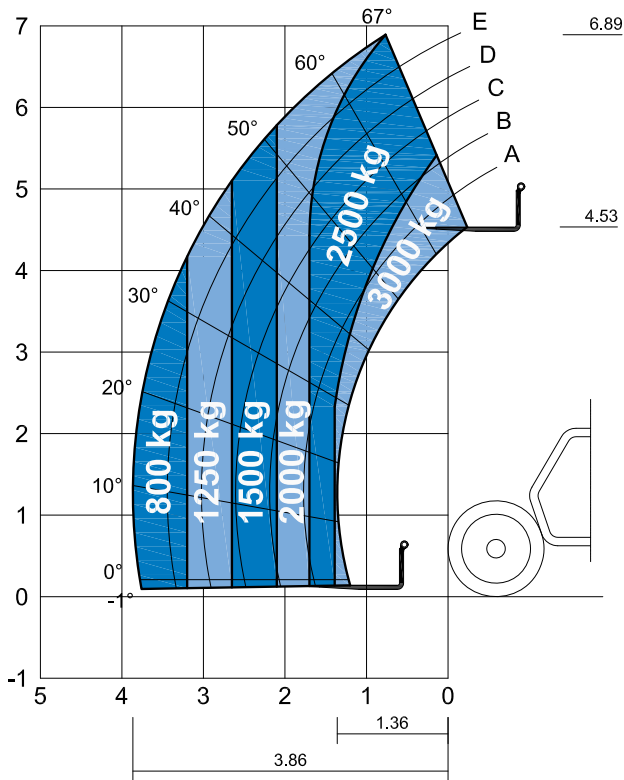

On tyres with fixed hook

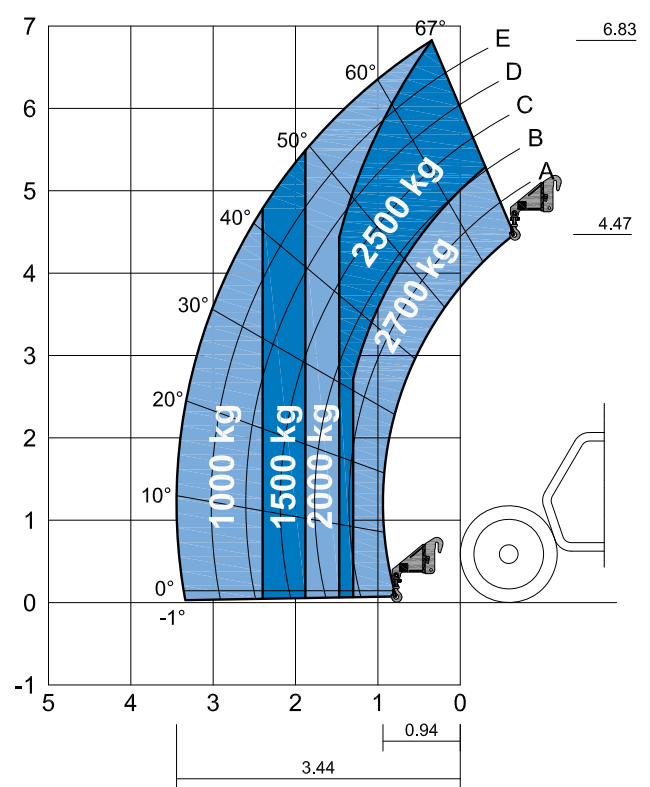

On tyres with 2 m jib

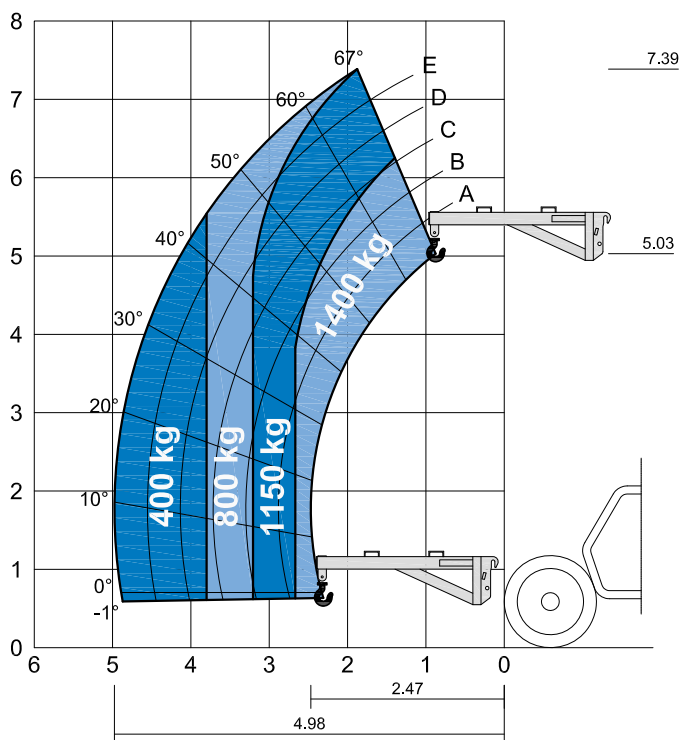

On tyres with side shift forks

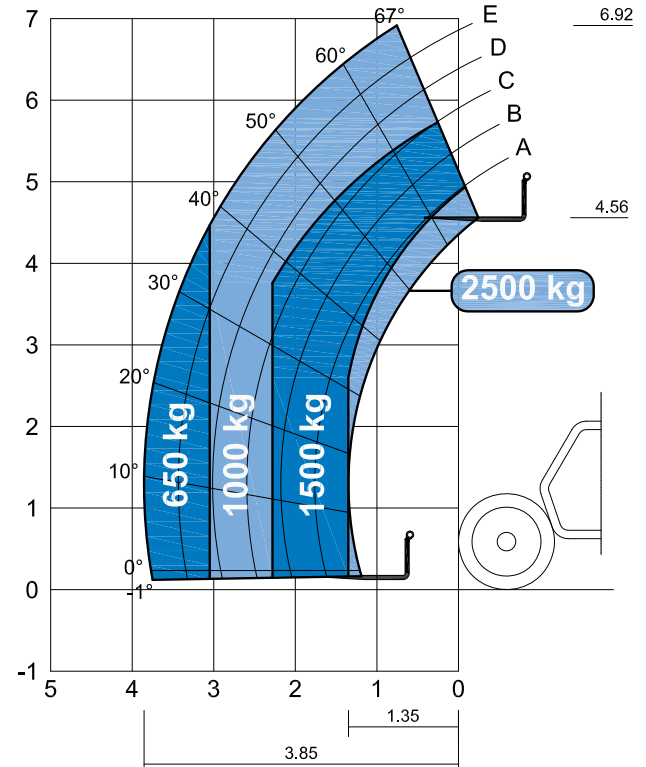

Load Charts

On tyres with 700 L GP Bucket

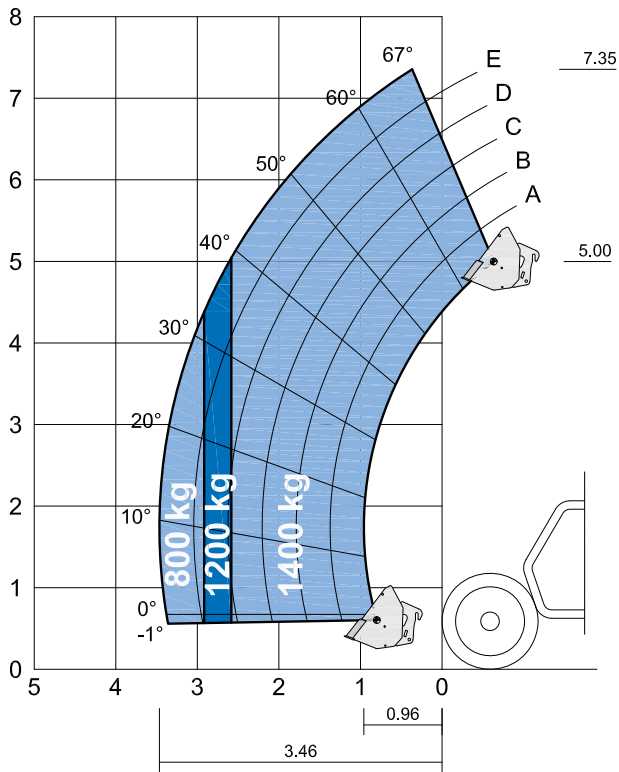

On tyres with 4-in-1 bucket 500 L

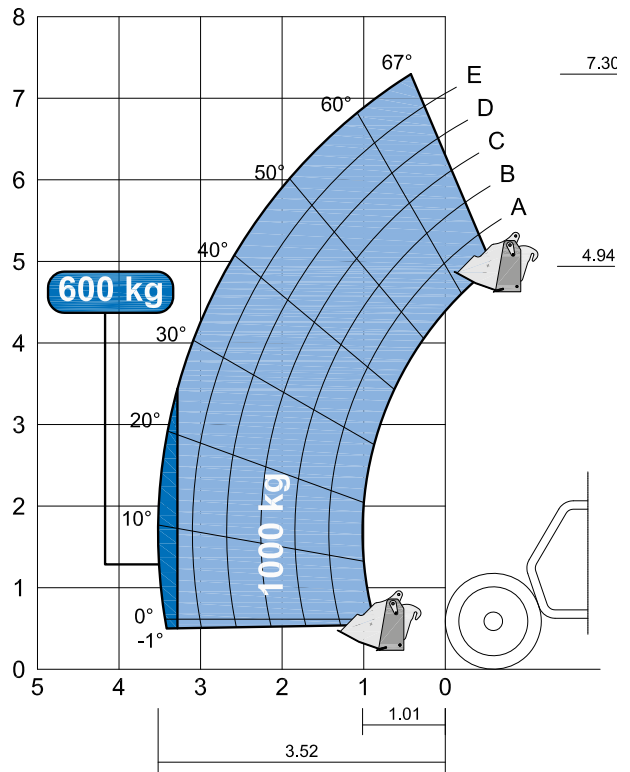

On tyres with fork rotator

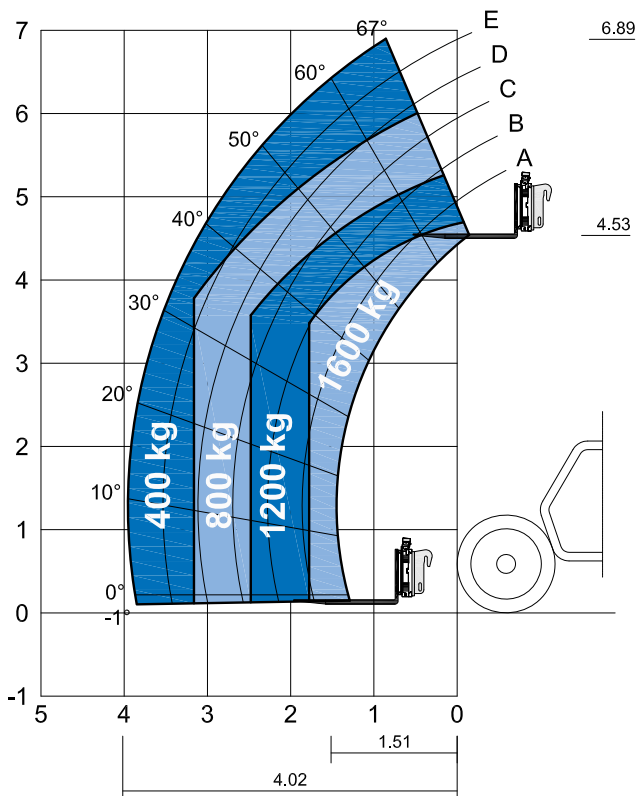

On tyres with extended forks

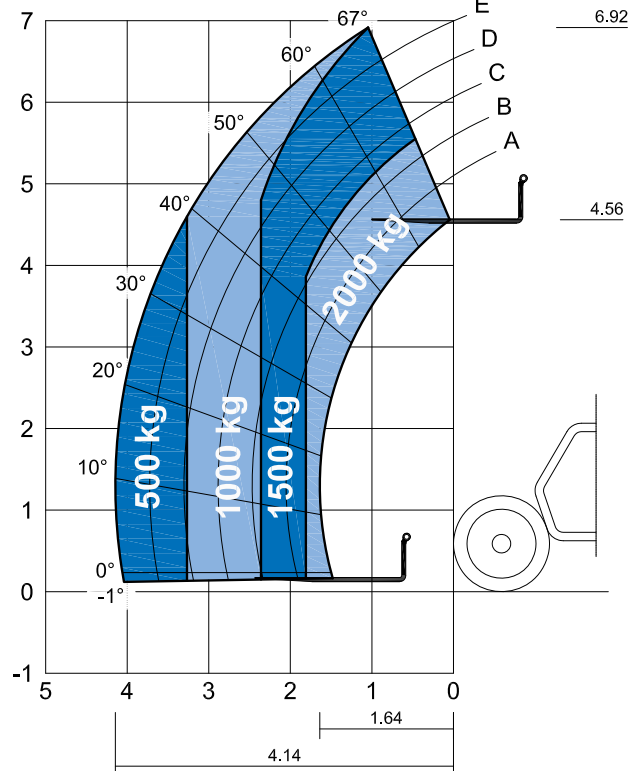

Features

Standard Features

Measurements

- 3,000 kg (6,614 lb) maximum lift capacity
- 6.89 m (22 ft 7 in) maximum lift height
- 3.86 m (12 ft 8 in) maximum forward reach

Productivity

- 4 Wheel Drive
- 4 Wheel Steer
- 3 Steering Modes: Front, Crab, Coordinated
- Power Assisted Steering
- Hydrostatic Transmission
- Limited Slip Differential on Front Axle
- Oil immersed Multi-disc brakes on front axle

Chassis & Tyres

- Side-mounted Engine for Easy Access and Maintenance
- Maintenance Collar
- Front & Rear Lights
- Two side view and rear fish eye mirrors
- Lockable fuel tank

Cabin

- Electro-proportional 4x1 Joystick
- Two-section door (glass upper/steel lower)
- Adjustable suspended seat
- Adjustable steering wheel
- Front & rear windscreen wipers
- Sunshield
- Roof protection grid
- Windshield protection grid
- Battery disconnection switch
- Self activated parking brake hydraulically released
- Road/jobsite switch
- Load Management System (LMS) with:
 - Dynamic colour coded load chart
 - 7" colour display
 - Reversing camera
 - Optional front camera
 - Optional iButton user access control

Cabin

- Use and Maintenance Handbook
- Air conditioning

Boom

- Main hydraulic line on boom
- Additional hydraulic line on boom
- Hydraulic quick coupling for attachments
- Angle and length indicators on boom

Power

- Deutz diesel 55.4 kW (74 hp), stage 3A

Tyres

- Air filled rough terrain tyres, 405/70-20" PR14. 8 holes wheel rim (DIN 70361)

Options & Accessories

Attachments

- Genie has a large range of attachments available. Please contact Genie or your nearest Genie telehandler dealer.



Genie – Toll free number 1800 788 633

Brisbane

HEAD OFFICE
33 Kimberley Street
Darra QLD 4076

Sydney

74 Glendenning Road
Glendenning NSW 2761

Melbourne

133 Logis Boulevard
Dandenong Sth VIC 3175

Adelaide

16-18 Nixon Road
Wingfield SA 5013

Perth

126 Sheffield Road
Welshpool WA 6106

Darwin

33 McCourt Road
Yarrowonga NT 0830

Genie USA

18340 NE 76th Street
P.O. Box 97030
Redmond, Washington
98073-9730

Distributed By:

Effective Date: May, 2018. Product specifications and prices are subject to change without notice or obligation. The photographs and/or drawings in this document are for illustrative purposes only. Refer to the appropriate Operator's Manual for instructions on the proper use of this equipment. Failure to follow the appropriate Operator's Manual when using our equipment or to otherwise act irresponsibly may result in serious injury or death. The only warranty applicable to our equipment is the standard written warranty applicable to the particular product and sale and we make no other warranty, express or implied. Products and services listed may be trademarks, service marks or trade names of Terex Corporation and/or their subsidiaries in the USA and many other countries. Genie is a registered trademark of Terex South Dakota, Inc. © 2018 Terex Corporation.